

# Kakati™

Vacuum Systems

An ISO 9001:2008 Company



The KAKATI high efficiency Pre-Separator for  
Maximum Separation | Minimum Floor Space | Low Maintenance | No Level Controls

# Kakati™

## Vacuum Systems

The liquid ring vacuum pumps can only take in so much water from its intake. Any increase in water from inlet pipeline effects the pumps functionality. To overcome this problem we have developed the pre separator pumps.

### Advantages of kakati pre-seperator pumps.

- Semi open impeller design—Provides positive prime even under continuously starved conditions.
- Flange mounted directly onto the separator tank into the suction line for simple installation with minimum floor space.
- Eliminates suction piping and the need for hydrostatic leg.
- Minimizes NPSH requirements.
- Eliminates cavitation.
- Swing out hinge option allows inspection of the pump suction or quick access to the tank interior.
- V-belt drives for performance flexibility.
- Corrosion and abrasion resistant materials for aggressive applications.
- Partially sealed and permanently lubricated bearings reduce maintenance and increase bearing life and time between overhauls.
- Eliminates the need for level control devices.

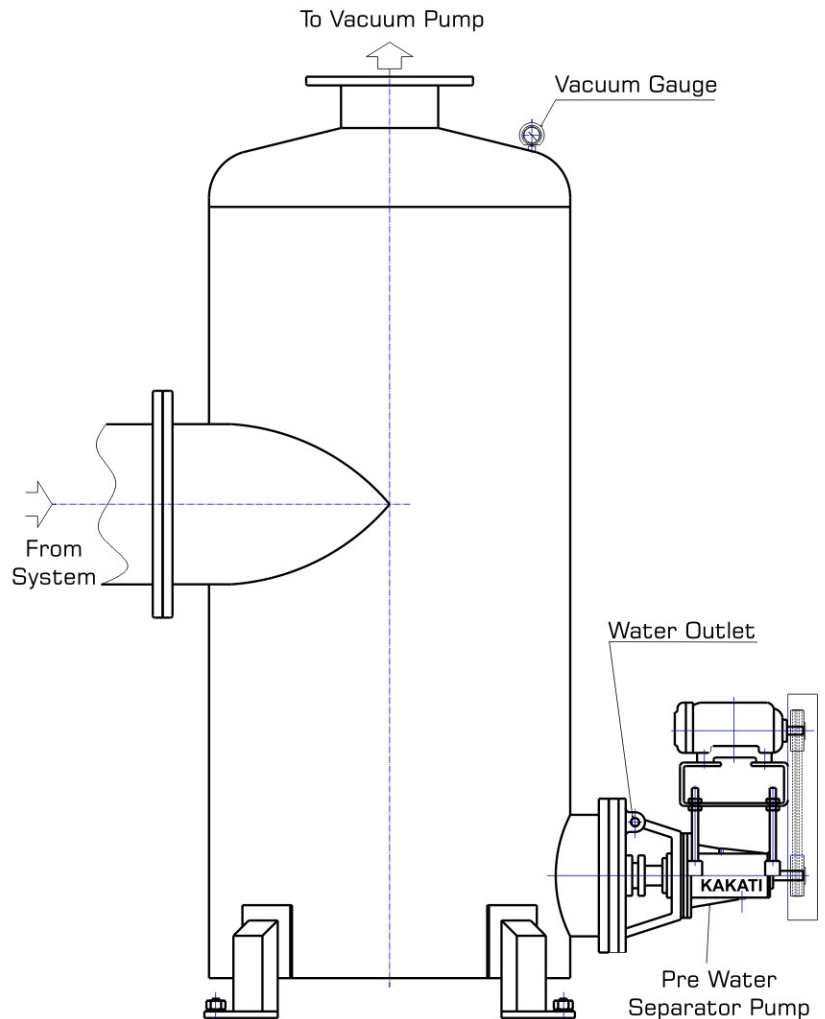

Pump Model	Max. Water Handling Capacity lpm.	Rec. Motor hp
KPS 45	500	5
KPS 90	1200	7.5
KPS 100	2200	10



## KAKATI KARSHAK INDUSTRIES PRIVATE LIMITED

Manufacturers of Liquid Ring Vacuum Pumps and Systems

Plot No. P-4/1, Road No.1, Nacharam Industrial Area, Hyderabad - 500 076. Telangana, INDIA.

Ph: +91 - 40 - 27153104/05, 27174522/74, 27171298, 27172704, Fax : +91 - 40 - 27171980,

marketing@kakatipumps.com, info@kakatipumps.com